

C-1a	1648	402	16	x1	1/1
C-1b	1648	402	16	x1	1/1
C-2	474	345	16	x2	1/1
C-3	340	382	16	x1	1/1
C-4	340	360	16	x1	1/1
C-5a	340	345	16	x1	1/1
C-5b	340	345	16	x1	1/1
C-6	646	334	16	x1	1/1
C-7a	478	160	16	x1	1/1
C-7b	478	160	16	x1	1/1
C-8	419	100	16	x2	1/1
C-9a	300	100	16	x2	1/1
C-9b	300	100	16	x2	1/1
C-10	447	305	3	x2	1/1
C-11	340	40	16	x2	1/1
C-12	964	38	16	x2	1/1
C-13	354	1629	3	x1	1/1
D-1	1370	165	16	x1	1/1
D-2	1370	165	16	x1	1/1

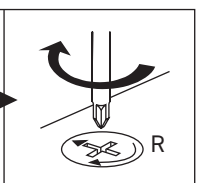

1

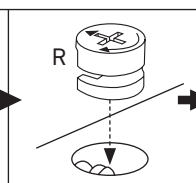
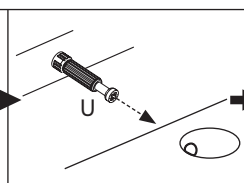
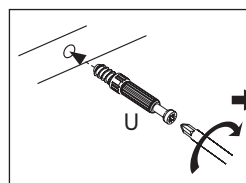
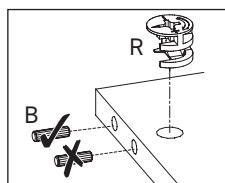
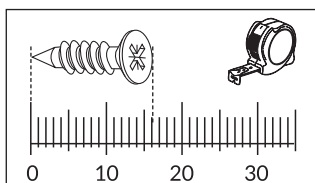
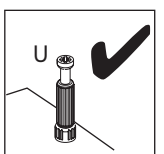
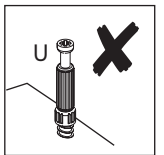
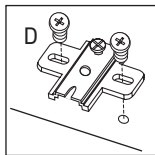
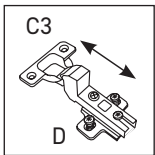
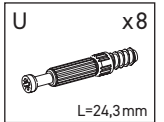
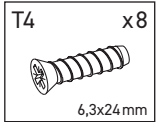
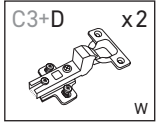
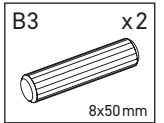
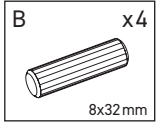
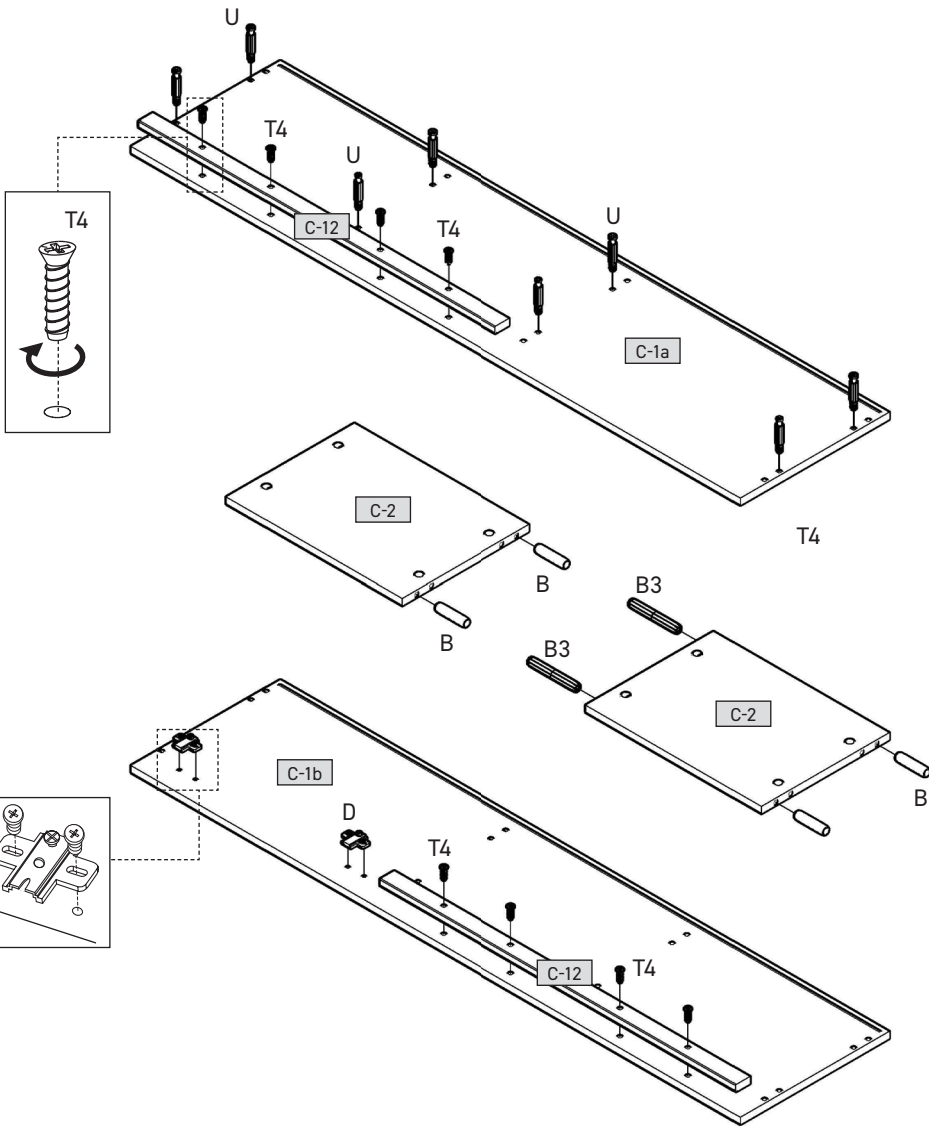

2

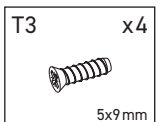
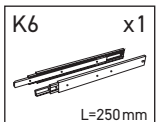
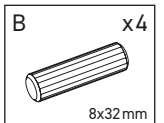
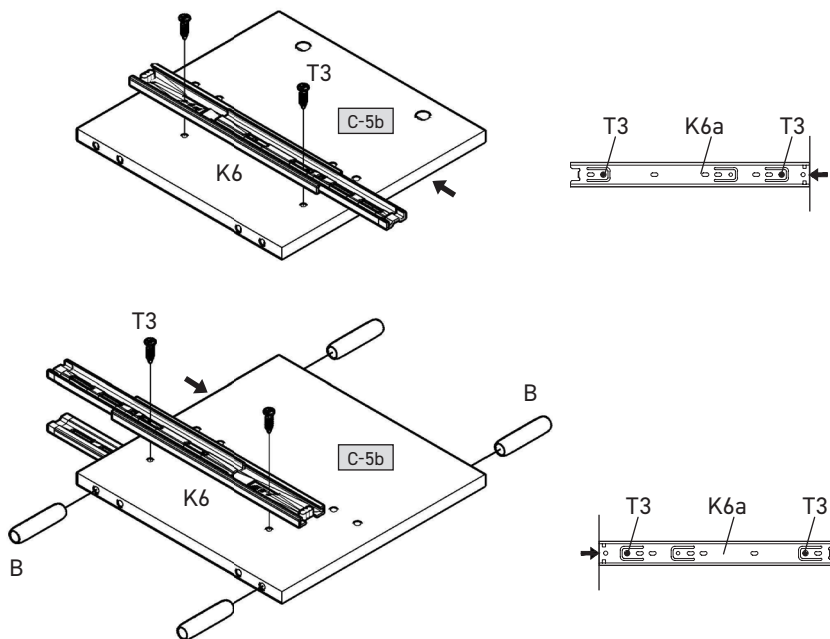
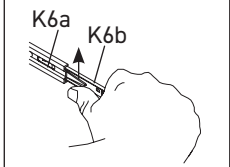
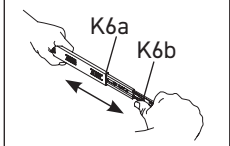
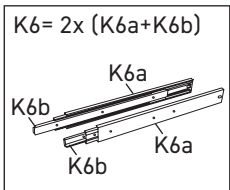
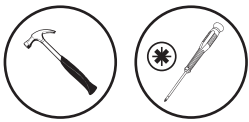

3

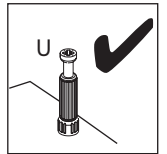
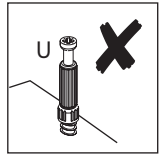
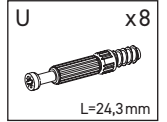
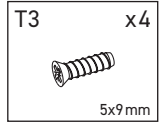
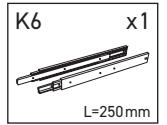
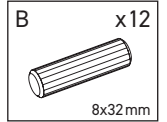
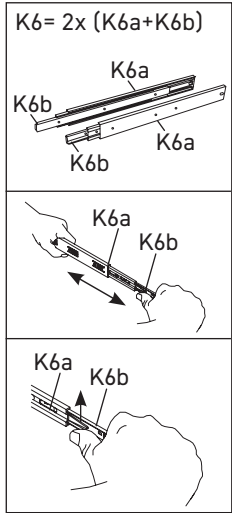
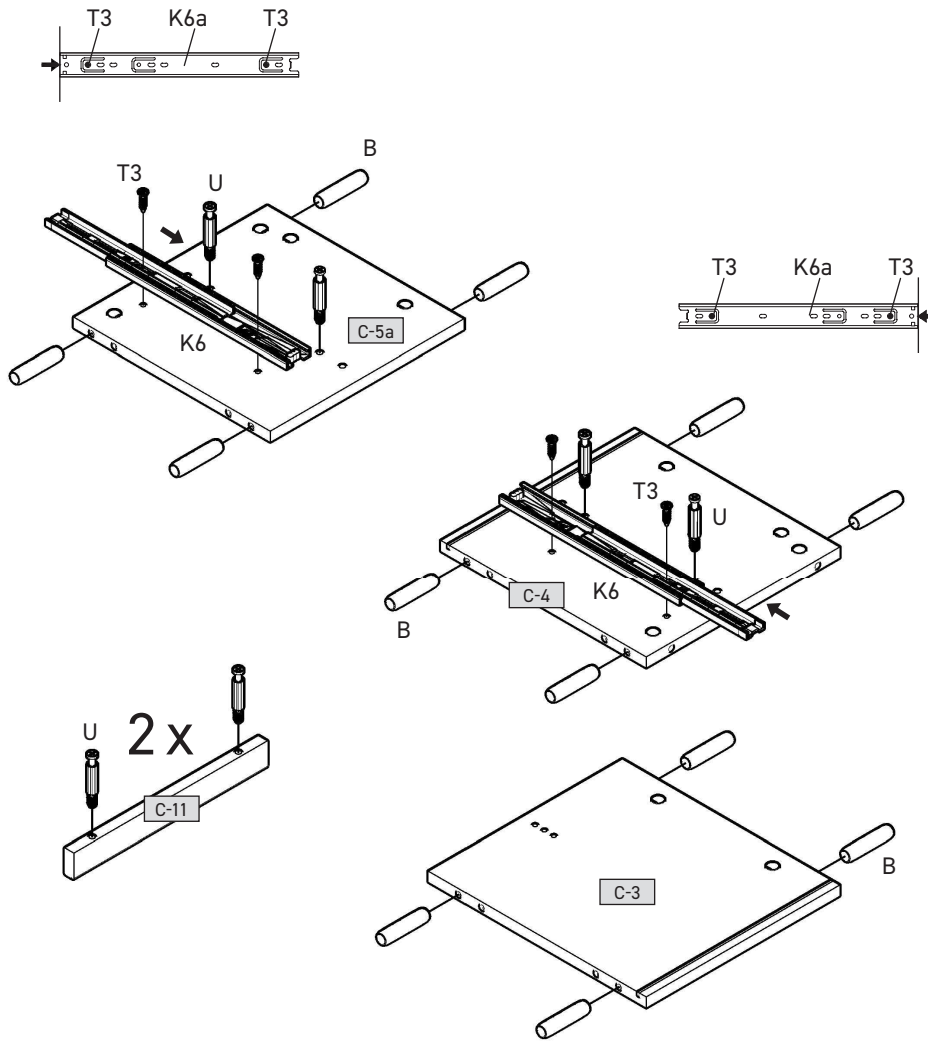

4

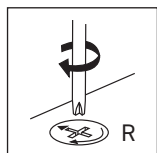
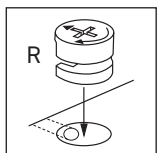
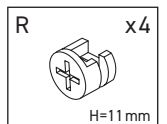
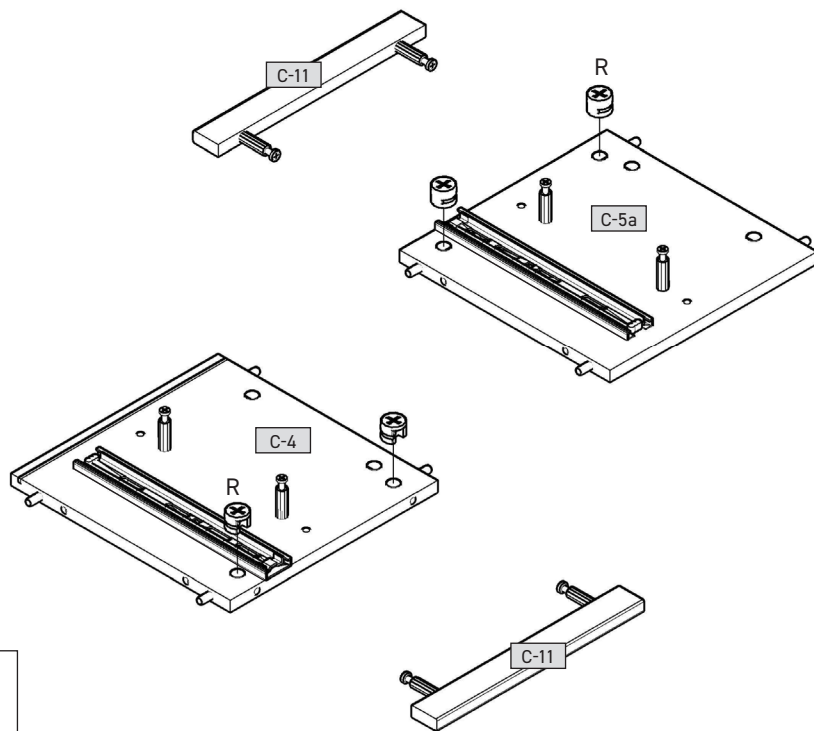

5

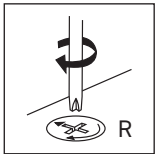
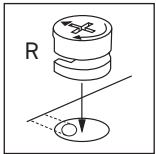
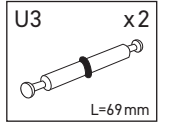
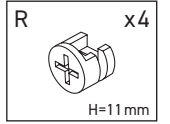
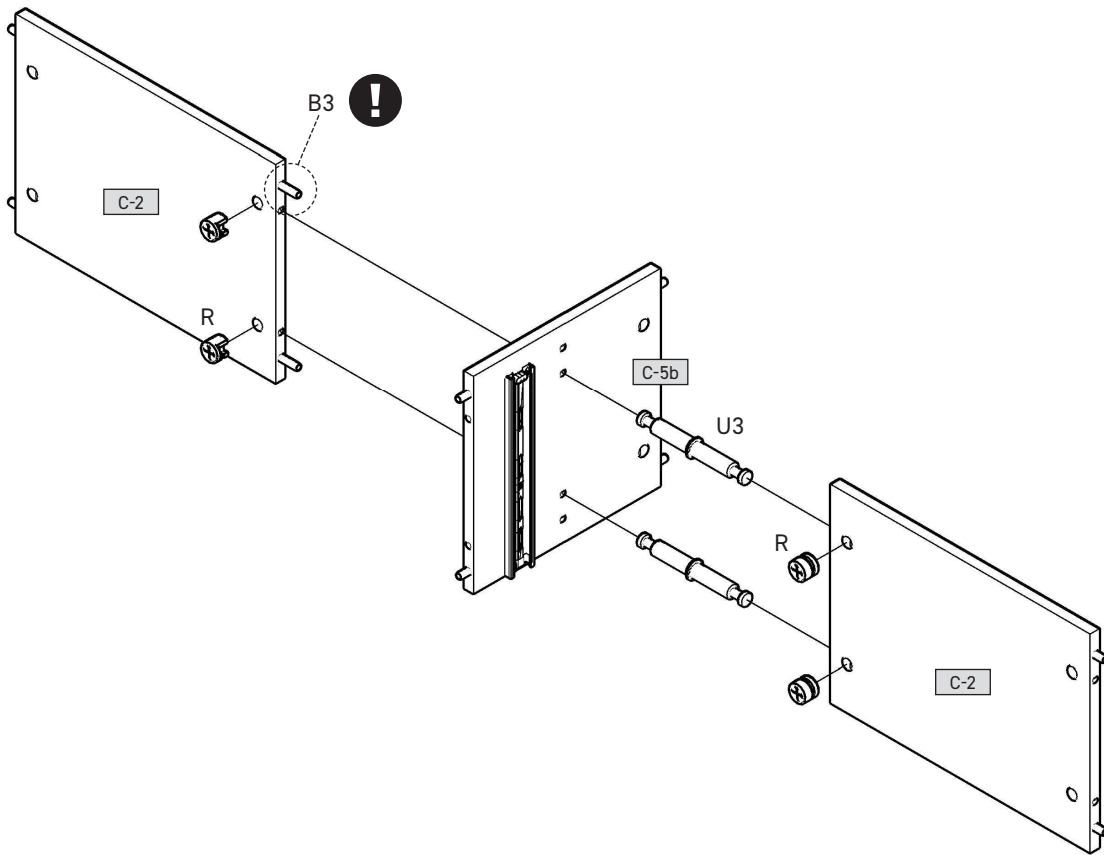

6

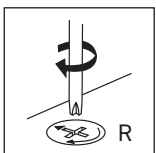
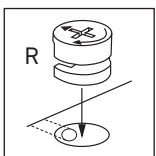
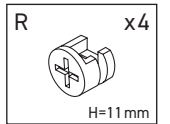
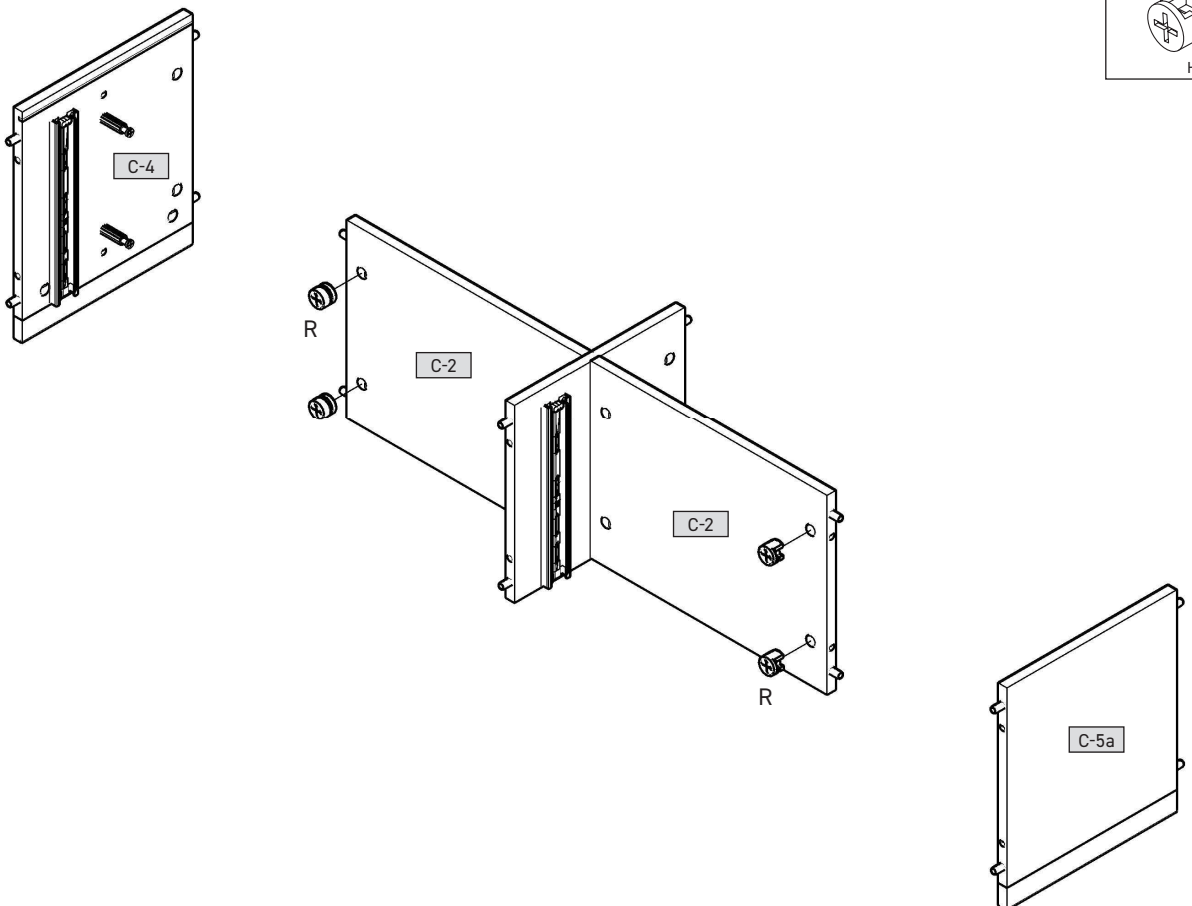

7

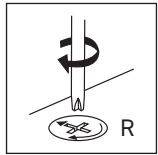
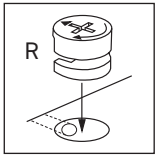
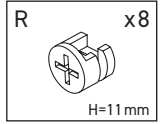
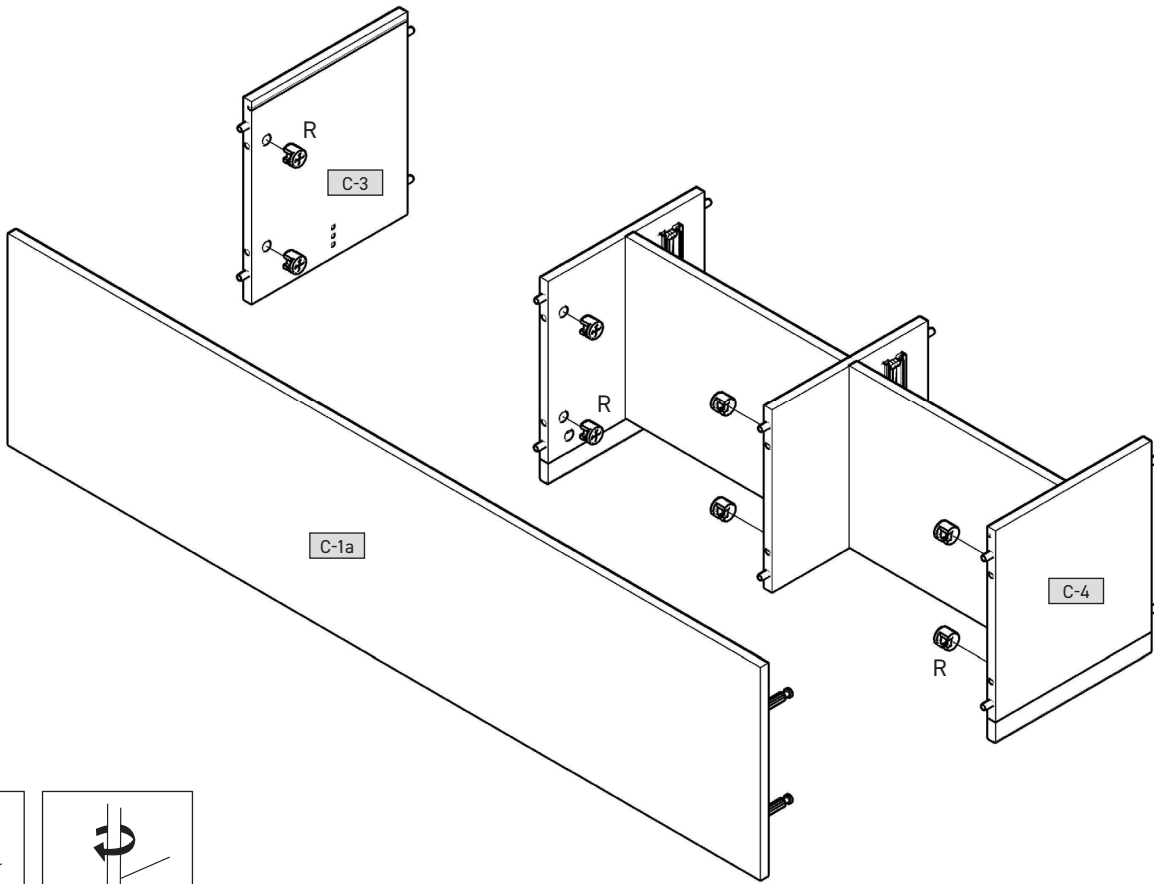

8

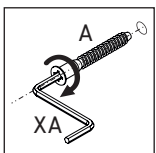
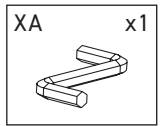
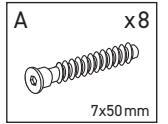
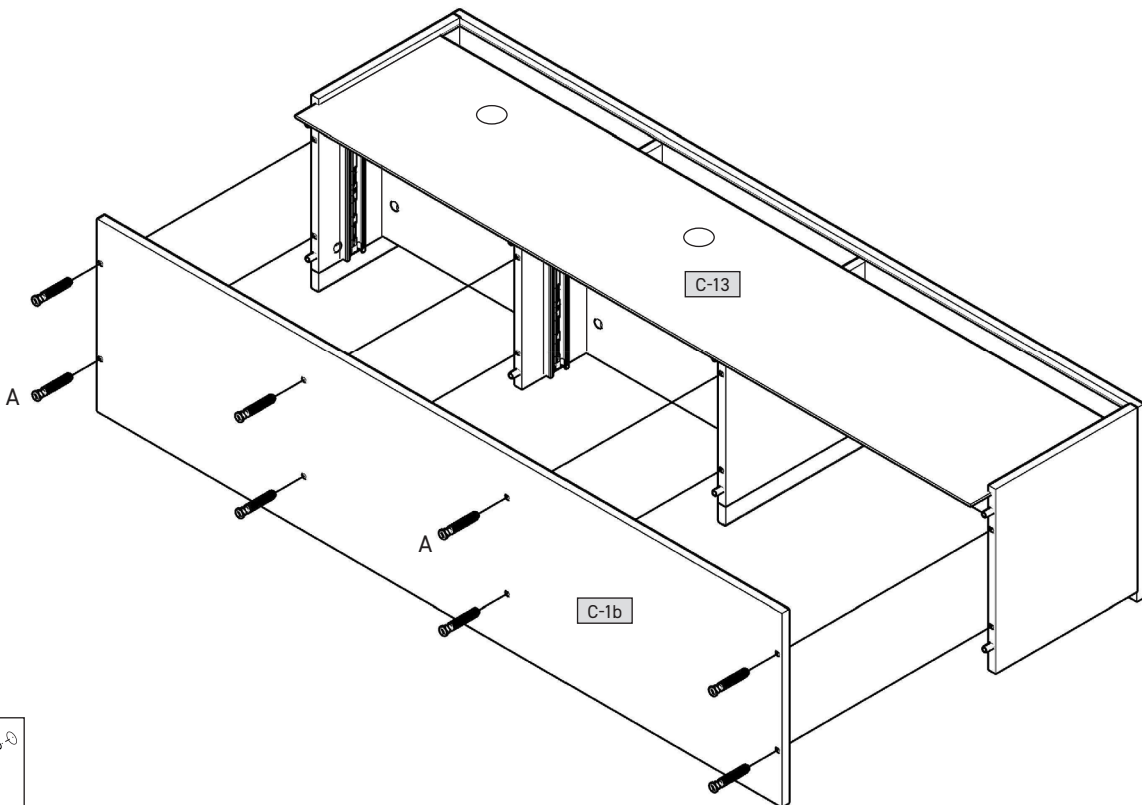

9

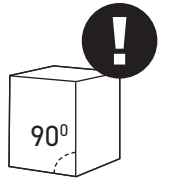
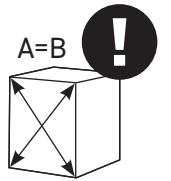
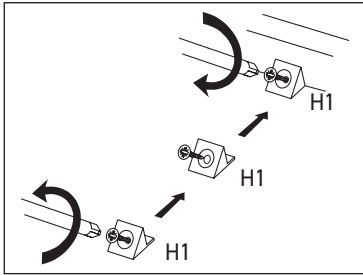
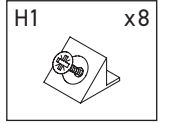
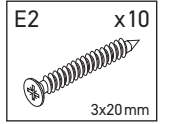
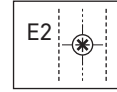
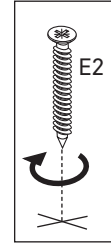
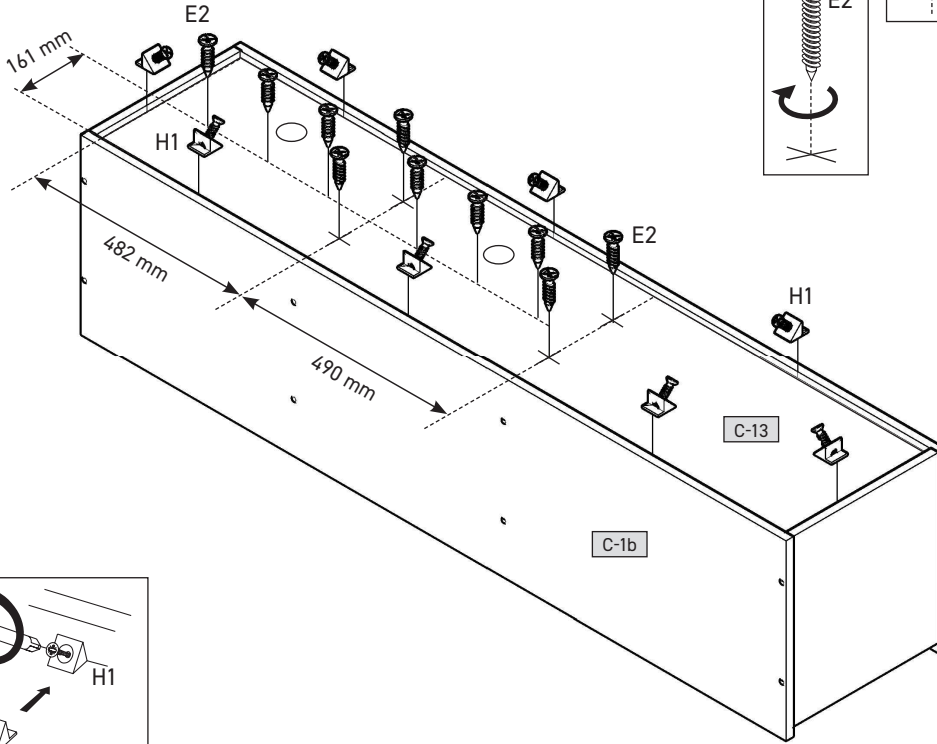

10

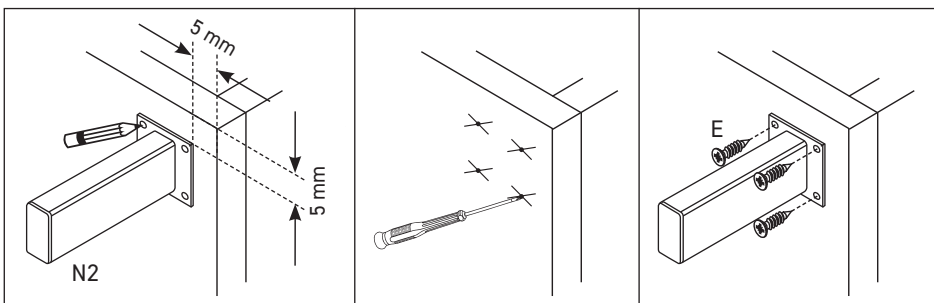
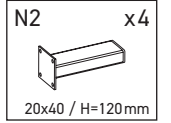
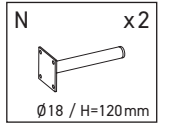
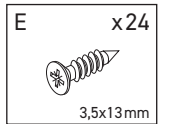
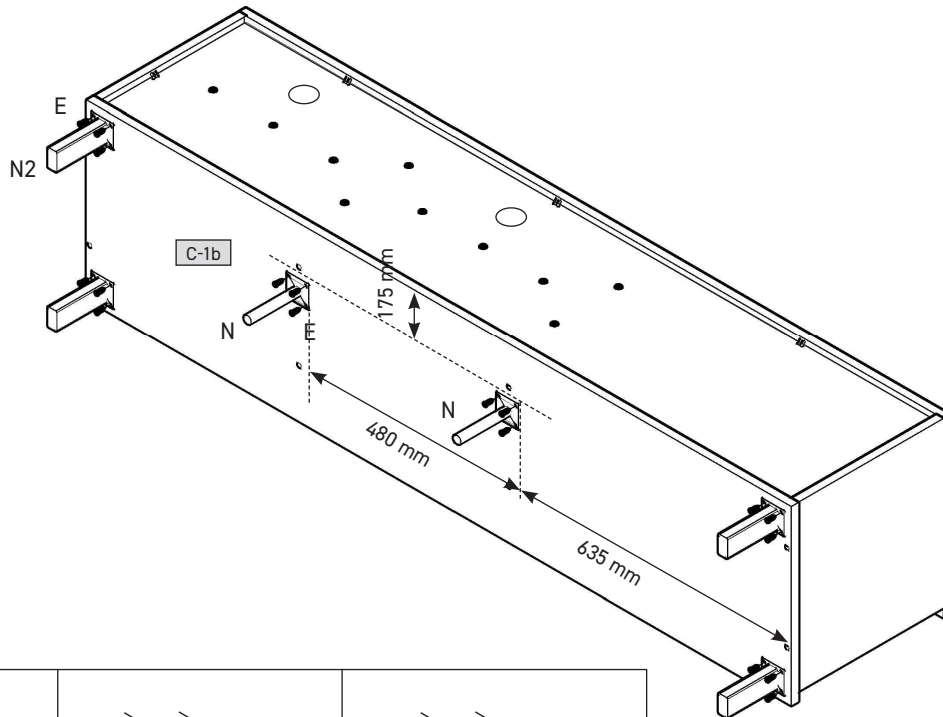

11

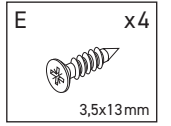
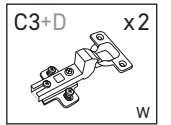
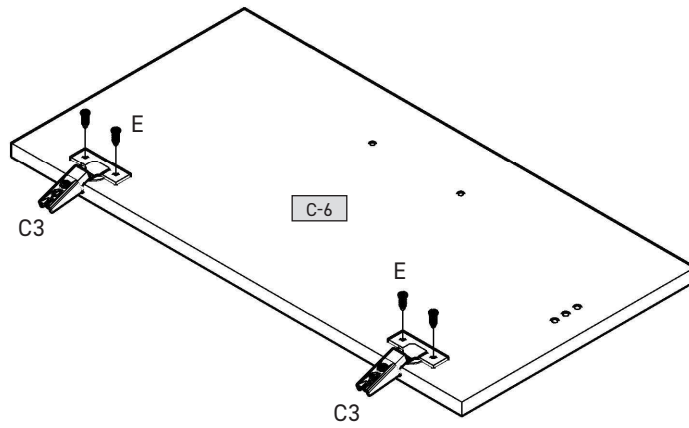
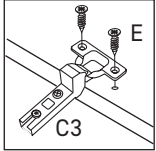

12

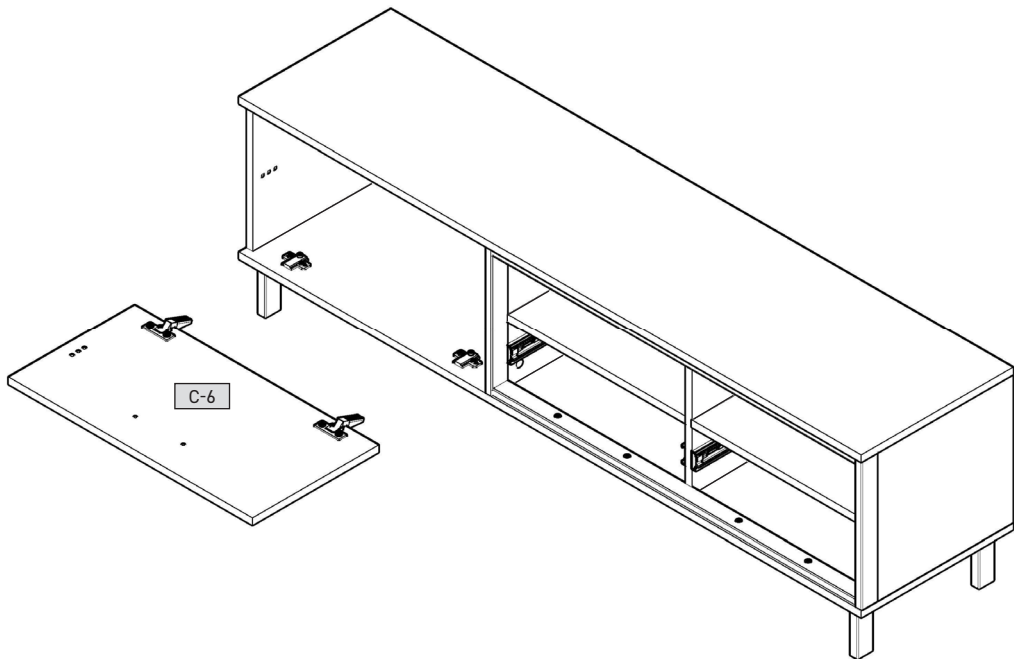
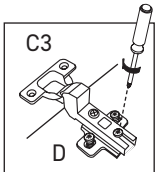
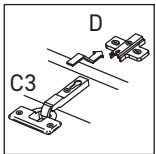

13

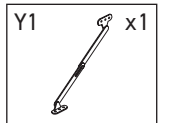
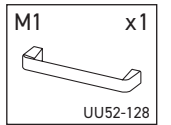
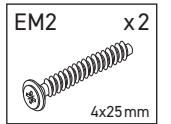
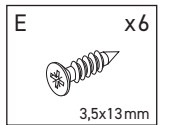
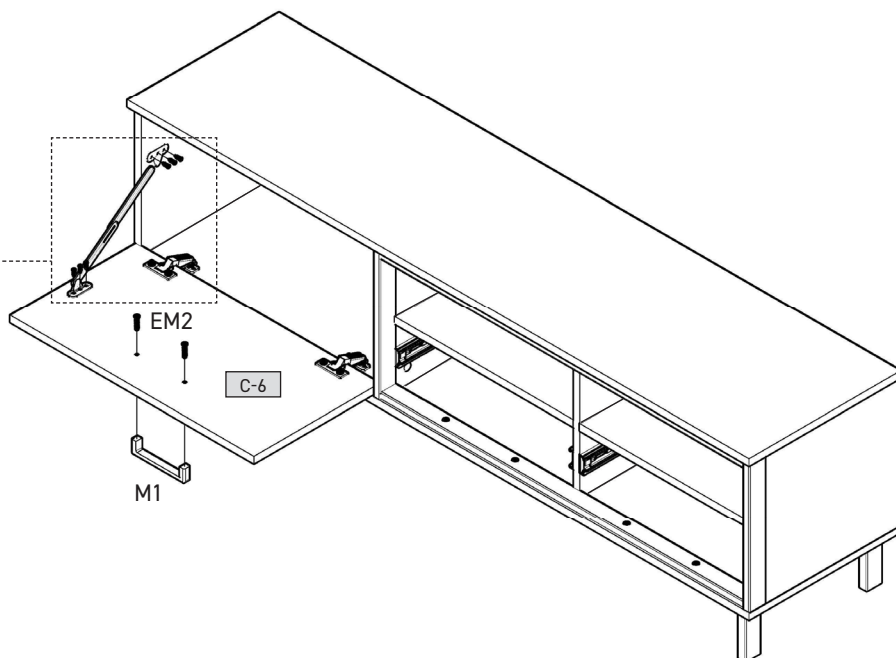
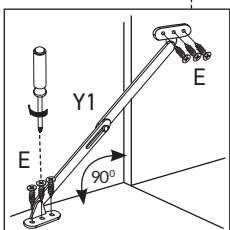

14

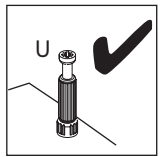
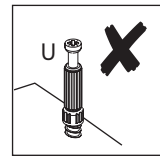
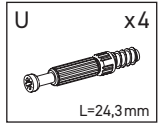
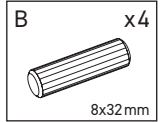
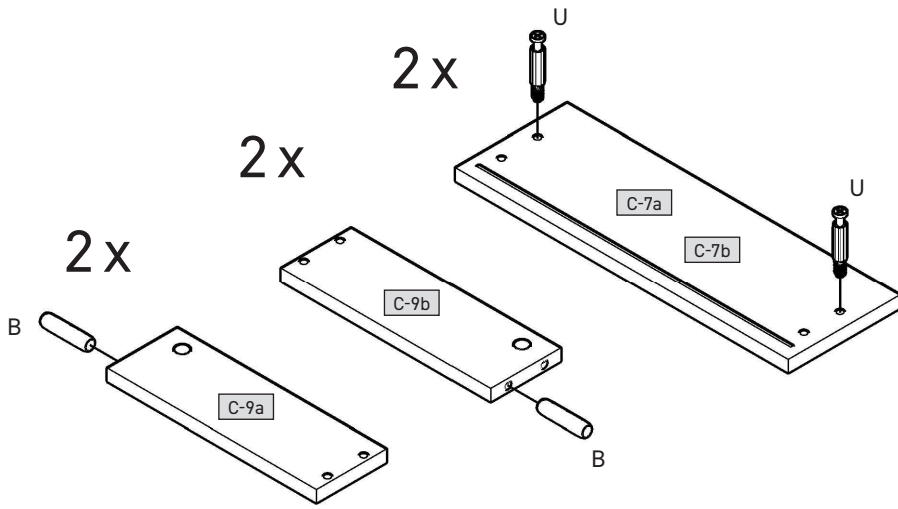

15

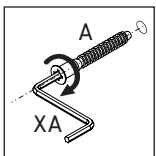
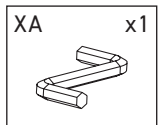
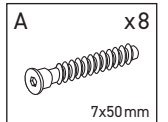
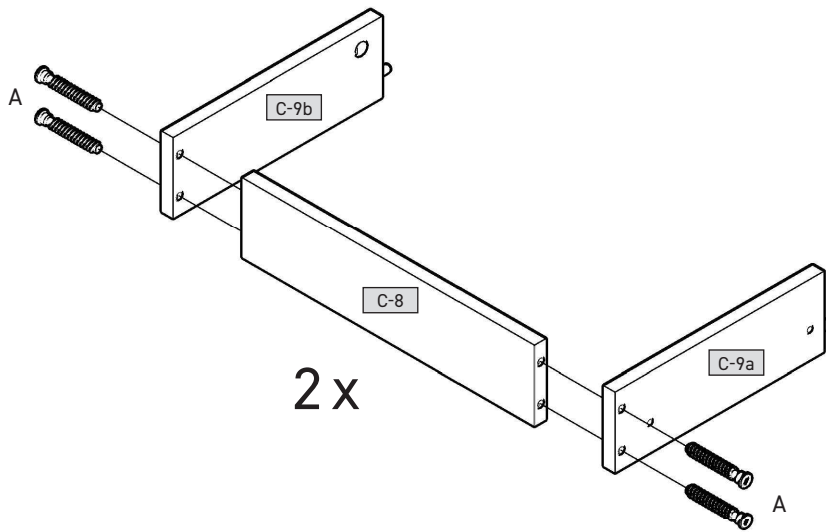

16

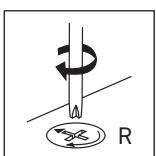
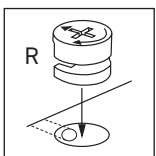
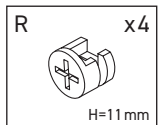
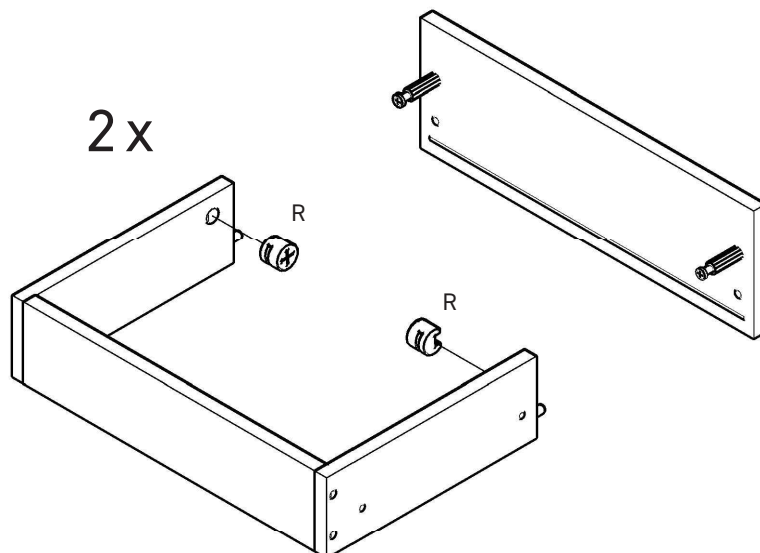

17

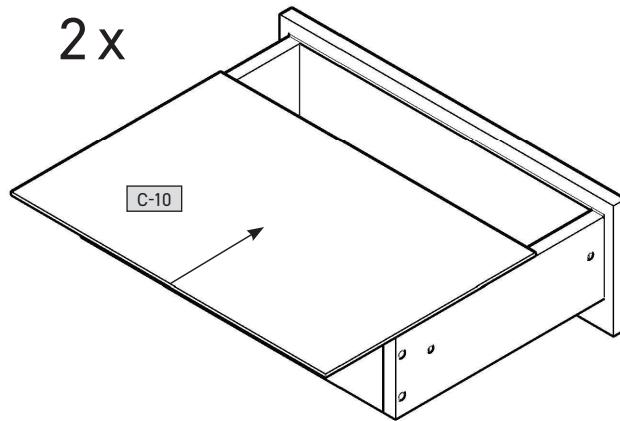

18

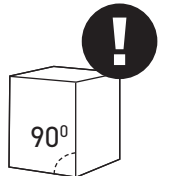
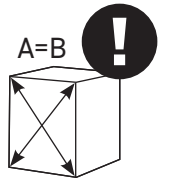
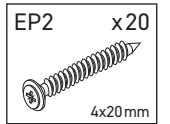
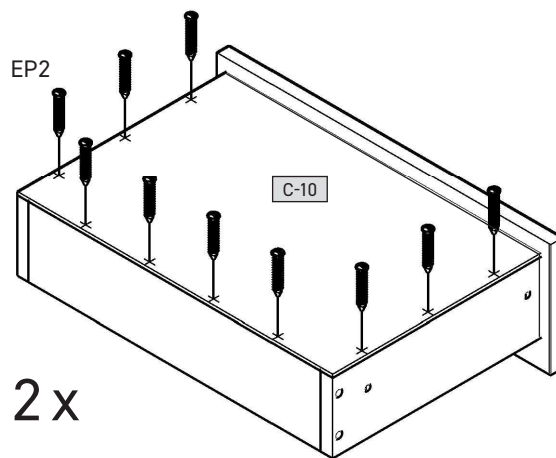
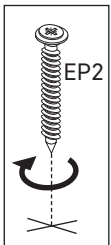

19

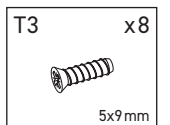
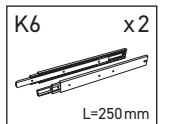
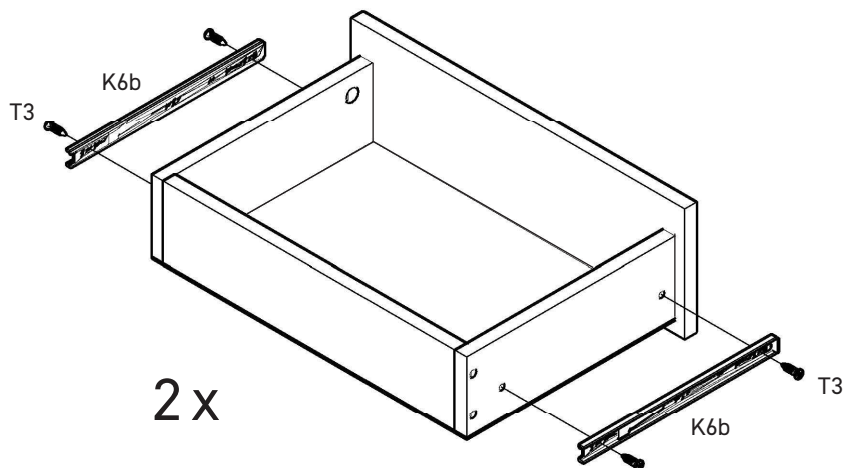

K6 = 2x (K6a + K6b)

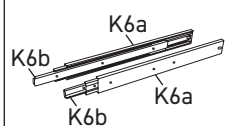

20

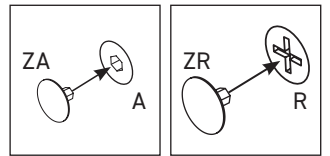
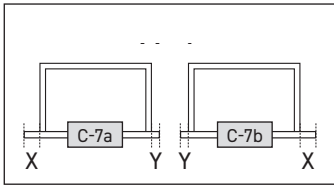
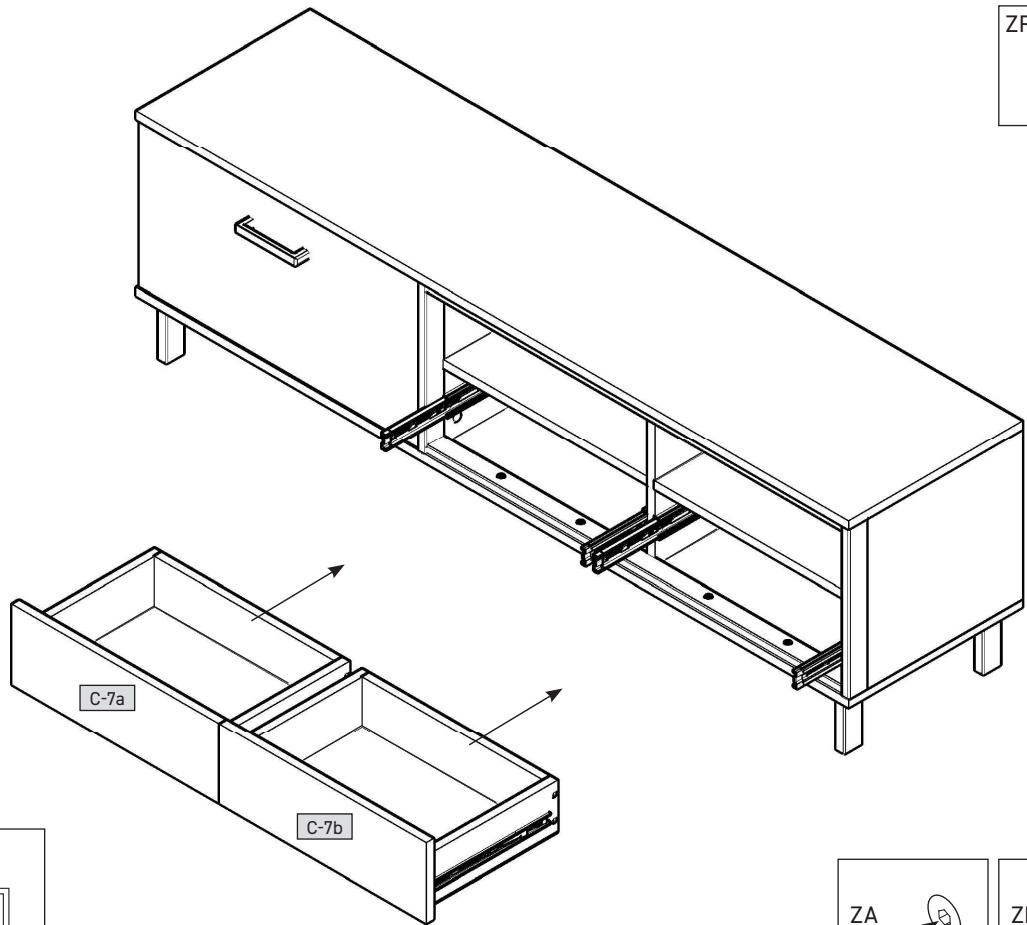
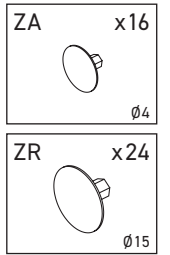
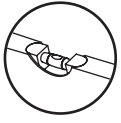

21

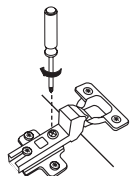
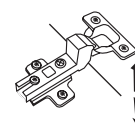
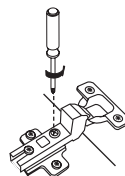
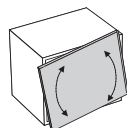
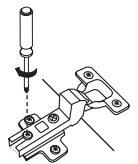
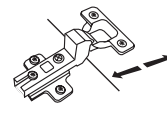
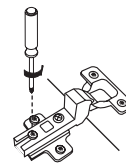
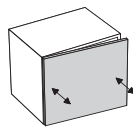
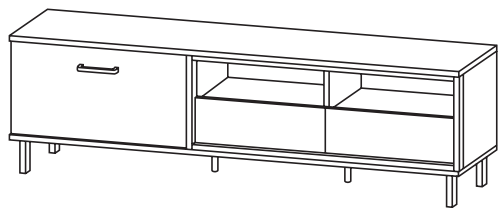
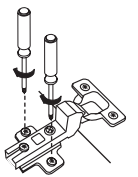
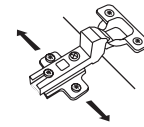
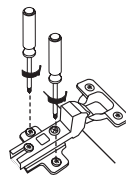
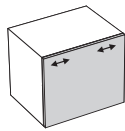

22

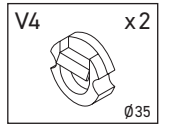
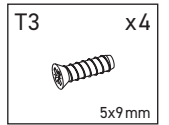
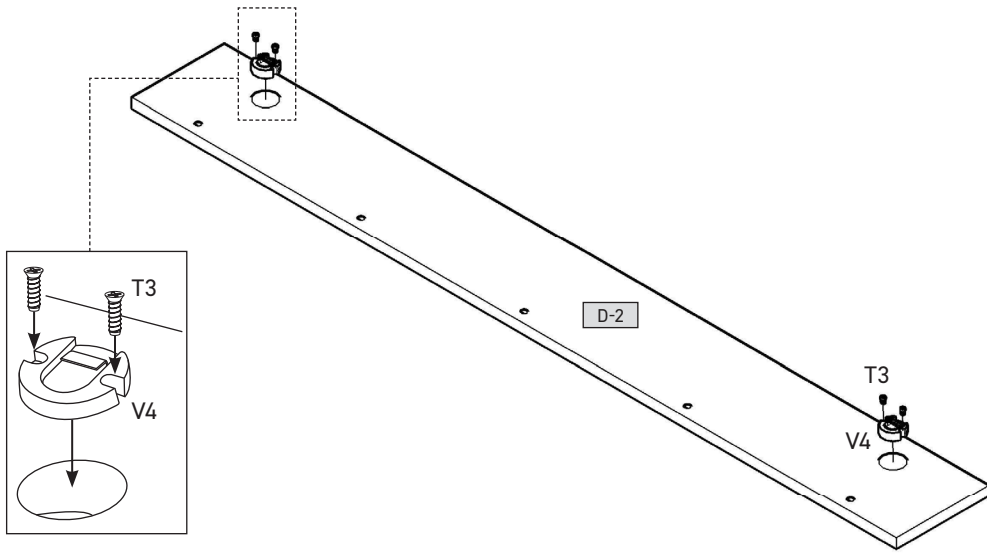
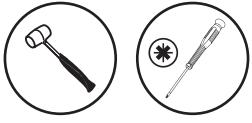

23

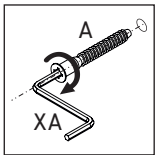
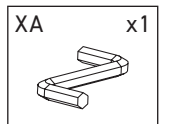
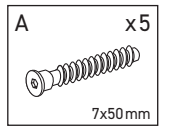
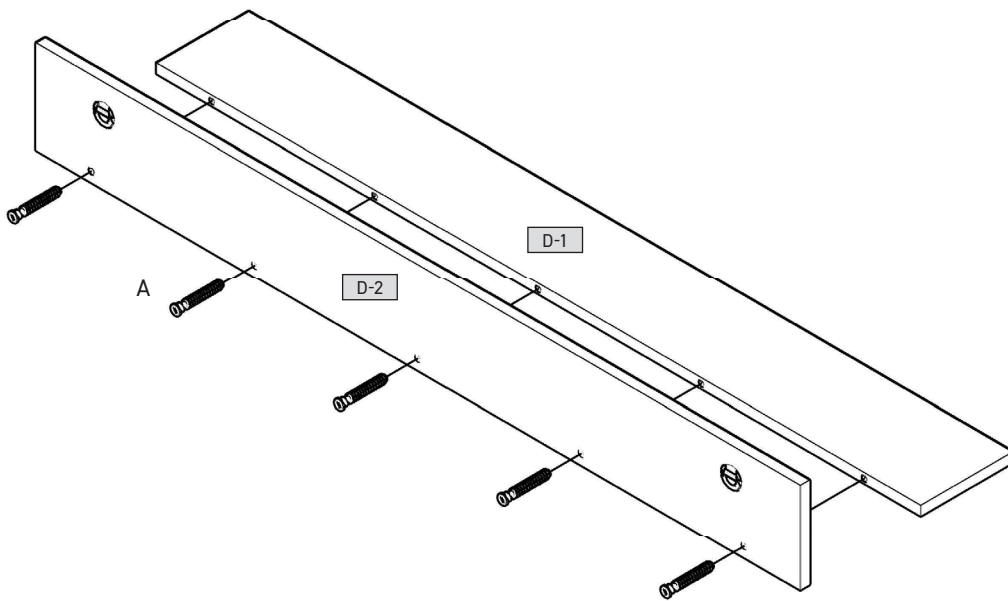

24

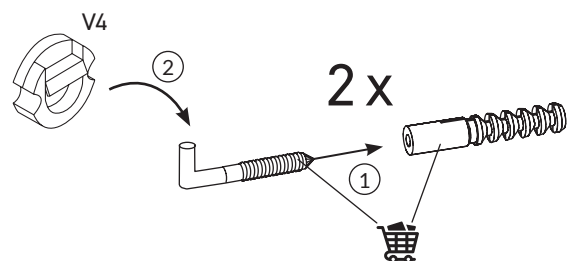
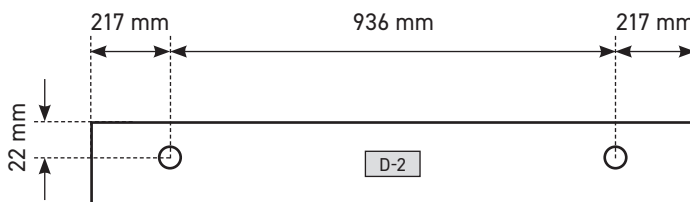
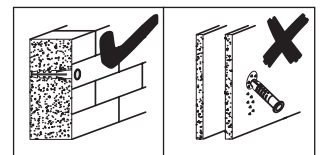
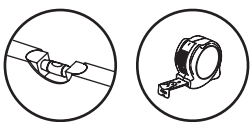

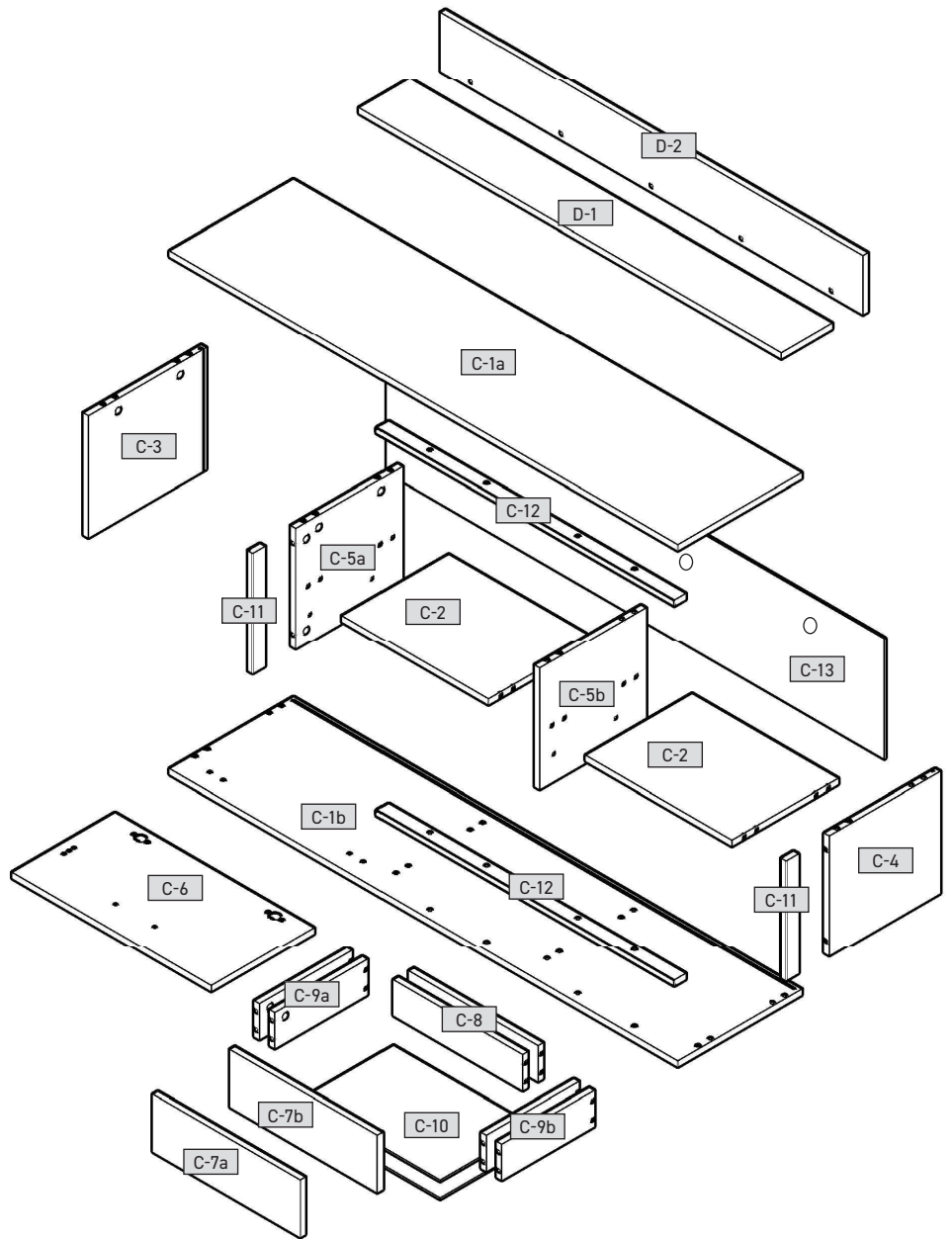
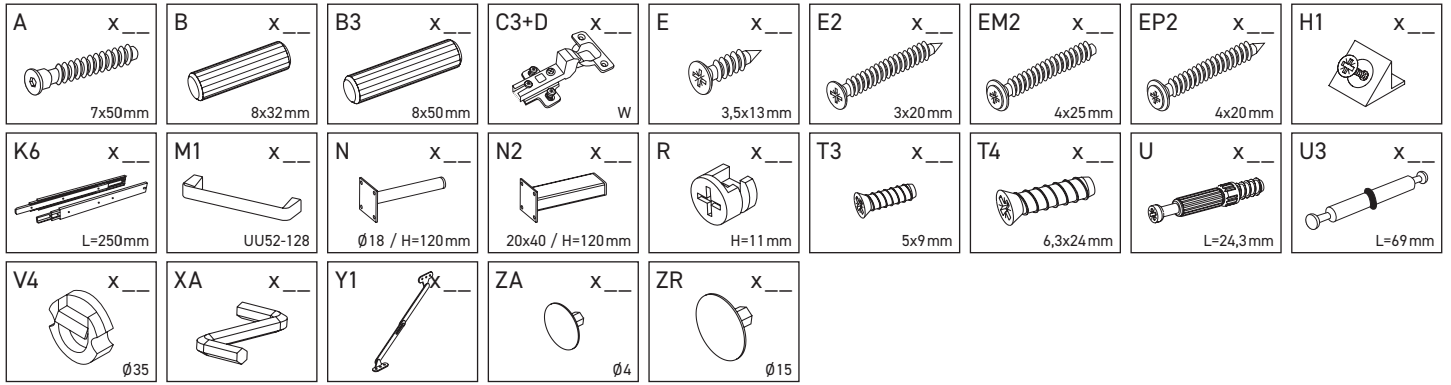

C-1a	1648	402	16	x 1	1/1
C-1b	1648	402	16	x 1	1/1
C-2	474	345	16	x 2	1/1
C-3	340	382	16	x 1	1/1
C-4	340	360	16	x 1	1/1
C-5a	340	345	16	x 1	1/1
C-5b	340	345	16	x 1	1/1
C-6	646	334	16	x 1	1/1
C-7a	478	160	16	x 1	1/1
C-7b	478	160	16	x 1	1/1
C-8	419	100	16	x 2	1/1
C-9a	300	100	16	x 2	1/1
C-9b	300	100	16	x 2	1/1
C-10	447	305	3	x 2	1/1
C-11	340	40	16	x 2	1/1
C-12	964	38	16	x 2	1/1
C-13	354	1629	3	x 1	1/1
D-1	1370	165	16	x 1	1/1
D-2	1370	165	16	x 1	1/1

